

**INSTALLER: LEAVE THIS MANUAL WITH THE PROUD NEW OWNER.
CONSUMER: PLEASE READ AND RETAIN FOR FUTURE REFERENCE.**

IMPORTANT: READ THESE INSTRUCTIONS CAREFULLY BEFORE INSTALLATION!

Le Griddle



Gas Model Owner's Manual

Installation, Operation, Maintenance, Instructions, & Parts List

Models:

OML40P3, OML75P3, OML75P6, OML75C3, OML75C6,
OML105P3, OML105P6, OML105C3, OML105C6

This owner's manual was updated in April 2026.

**For the latest news and product updates, please visit:
LeGriddle.com | CS@LeGriddle.com**

Message to the proud owner

Thank you for your purchase. We'd like to welcome you to the Le Griddle family, and we look forward to being a part of your home for years to come.

Read this manual carefully to understand all the instructions about how to install, operate, and maintain your griddle for optimum performance and longevity.

Keep this manual in a safe place for future reference.

For any assistance, you can contact us via www.LeGriddle.com

Make sure to provide the model number and serial number of the griddle, which are located on your Le Griddle Box. We recommend writing it down below and keeping this manual in a safe place.

Series Number: _____

Contents:

For Your Safety	3-9
First Time Operation	9
Outdoor Ventilation & Vent Hood Requirements	10-12
Indoor Installation & Vent Hood Requirements	13-15
Gas Connections	16-19
Outdoor Kitchen Installation	20-21
Counter-Top Installation	22
Cart Installation	23
Technical Details	24
Initial Use	25-26
Cleaning & Maintenance	27-31
Storage	32
Electrical Details	32
Gas Conversion	33
Parts & Diagram	34
Warranty	35

WARNING

To reduce the risk of fire, electric shock, or injury, read and follow these basic precautions before operating your griddle.

GRIDDLE INSTALLATION

This gas griddle must be installed in accordance with all local codes.

If installation is planned in an area with no local codes, the gas griddle must be installed in accordance with the National Fuel Gas Code write ANSI Z223.1/NFPA54, NFPA 58, and CSA B149.2 storage and handling of liquefied petroleum gases code, CSA B149.1 natural gas and propane installation code. Installation in Canada must be in accordance with the standard CAN/CGA- B149.2.T.

WARNING: Improper installation, adjustment, alteration, service, or maintenance can cause injury or property damage, and void the warranty. Refer to this manual. Read the installation, operating, and maintenance instructions thoroughly before installing or servicing this equipment.

FOR YOUR SAFTEY

IF YOU SMELL GAS:

1. If you smell gas, immediately turn all control knobs to the OFF position and shut off the gas supply.
2. Extinguish any open flames.
3. Open lid to vent.
4. If odor continues, keep away for the appliance, and **IMMEDIATELY** call your gas supplier or fire department.
5. Do not try to light the appliance.
6. Do not use a cell phone, flip any switches, or create any sparks.
7. Open any windows or doors.

HAVE YOUR INSTALLER SHOW YOU WHERE THE GAS SHUT OFF IS LOCATED

NOTE: The manufacturer cannot be held responsible for damage or injury caused by improper use or installation of the appliance.

FOR YOUR SAFETY

- 1. Do NOT store or use gasoline, caustic, or other flammable vapors and liquids in the vicinity of this or any other appliance.**
- 2. An LP Cylinder not connected for use shall not be stored in the vicinity of this or any other appliance.**

TESTED IN ACCORDANCE WITH ANSI STANDARD FOR OUTDOOR COOKING GAS APPLIANCES.

Check your local building codes for the proper method of installation. In the absence of local codes, this unit should be installed in accordance with the National Fuel Gas Code ANSI Z223.1/NFPA 54, NFPA 58, CSA B149.1 natural gas installation code or CSA B149.2, propane installation code.

CALIFORNIA PROPOSITION 65- !!! WARNING !!!

Some by-products which are on the list of substances which are known by the State of California to cause cancer or reproductive harm. California law requires business to warn customers of potential exposure to such substances. To minimize exposure to these substances, always operate this unit according to the use and care manual, ensuring you provide good ventilation when cooking with gas.

STATE OF MASSACHUSETTS !!! WARNING !!!

Massachusetts requires all gas be installed using a plumber or gas fitter carrying the appropriate Massachusetts license. All permanently-installed natural gas or propane installations require a "T" handle type manual gas valve be installed in the gas supply line to this appliance. This does not apply to portable propane installations using a 20 pound cylinder.

IMPORTANT : REMOVE ALL PROTECTIVE FILM BEFORE USE

SAFETY!

BEWARE OF SPIDERS



CAUTION: BURNER TUBES MUST BE INSPECTED AND CLEANED.

Spiders and small insects occasionally spin webs or make nests in the burner tubes. These webs can lead to a gas flow obstruction, which could result in a fire in and around the burner tubes. This type of fire is known as “FLASH-BACK” and can cause serious damage to your appliance and create an unsafe operating condition for the user. Although an obstructed burner tube is not the only cause of “FLASH-BACK,” it is the most common cause, and frequent inspection and cleaning of the burner tubes is necessary.

⚠ WARNING

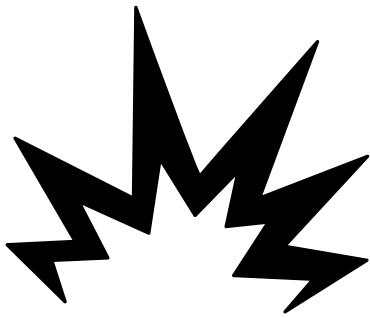

EXPLOSION HAZARD

DO NOT use the griddle as a storage area for flammable or caustic materials. Keep the area clear and free from combustible, gasoline, swimming pool chemicals, and other flammable vapors and liquids. Failure to do so can result in death, explosion, or fire.

IMPORTANT SAFETY INSTRUCTIONS

KEEP THESE INSTRUCTIONS FOR FUTURE REFERENCE

- Read and follow all instructions carefully before using this appliance. When operating gas appliances, basic safety precautions must always be observed.
- Le Griddle is not responsible for damage to property or injury to persons resulting from improper installation or operation.
- It is essential to follow these safety rules to reduce the risk of fire, property damage, or personal injury caused by improper installation or operation. Read all instructions carefully and follow all applicable local codes.
- This appliance is not intended for use by persons (including children) with reduced physical, sensory, or mental capabilities, or by individuals lacking experience or knowledge, unless they are properly supervised or instructed by a person responsible for their safety.
- Some parts of the appliance may become hot during use. Keep children away from the appliance at all times.

SAFETY INSTRUCTIONS CONTINUED ON PAGE 6

SAFETY INSTRUCTIONS CONTINUED-

- Never leave the appliance unattended while in operation.
- Do not move the appliance while it is in use.
- Use this appliance only for its intended purpose.
- The use of accessories not recommended by the manufacturer may result in injury or damage.
- Keep clothing, towels, and all flammable materials away from the appliance. Avoid wearing loose-fitting or long sleeves while operating the appliance.
- If you smell gas, immediately turn all control knobs to the OFF position and shut off the gas supply.
- Never operate an appliance that has a gas leak.
- Use protective, heat-resistant gloves when handling hot components.
- To prevent carbon monoxide buildup, do not block any air vents.
- The underside of the appliance must remain well ventilated to ensure proper airflow to the burner(s).
- Place the appliance on a stable, non-combustible, dry surface, positioned away from edges and at least **24** inches from walls or heat-sensitive objects.
- Recommended cooking height is 33 to 37 inches from the ground for a comfortable working position.
- Close the gas cylinder valve or main gas supply valve after each use.
- Any modification of the appliance is dangerous and will void the warranty. Do not modify this appliance.
- Do not use an adjustable or high-pressure gas regulator.
- Do not obstruct ventilation openings around the frame.
- Do not use or store flammable liquids or vapors near the griddle.
- We recommend retaining the original packaging for storage or transport.
- NEVER use this appliance as a space heater. Doing so may result in carbon monoxide poisoning and overheating.
- Never use any part of the griddle, lid handle, or cart as a step, support, or aid for standing or rising.
- Misuse of the griddle, including stepping, leaning, or sitting on the cooking surface, may result in injury.
- Know the location of the gas shut-off valve and keep it easily accessible.
- After installation, check all gas connections using a soap-and-water solution. Never use an open flame to test for leaks

SAFETY INSTRUCTIONS CONTINUED-

- Do not repair or replace appliance parts unless this manual specifically instructs it. All other servicing must be performed by a qualified technician.
- Use a heat-resistant glove when opening the lid. Open slowly to allow heat and smoke to escape safely.
- Grease is highly flammable. Allow grease to cool completely before handling, and clean the grease tray regularly to prevent fires.
- Do not allow excess grease or liquids to accumulate in the drip tray, as this may create a fire hazard.
- Never use the griddle without the drip tray properly installed.
- Do not operate the appliance in high winds. For windy locations, a Le Griddle Wind Guard is recommended (Item Numbers: LGUWG & LGWGE). Do not block airflow at the front or vented areas. Install the appliance facing prevailing winds to reduce drafts that may affect performance.
- The surface of the unit may be hot even though they appear dark in color. Areas near the cooking surface may become hot enough to cause burns. During and after use, do not touch the griddle or surrounding areas, and do not allow clothing, potholders, or other flammable materials to contact these surfaces until they have cooled sufficiently.
- Do not heat or warm unopened food containers. Pressure buildup may cause the container to burst, resulting in injury.
- To reduce bubbling and splattering, heat oils slowly and use no more than a low-to-medium heat setting. Hot oil can cause severe burns and injury.
- Never place a pan or container of hot oil directly on the griddle surface.
- Always keep the appliance clean and free of grease buildup to reduce the risk of grease fires.
- Never attempt to extinguish a grease fire with water or any other liquid.
- Keep a fire extinguisher ready at all times:
 - Class ABC for residential
 - Class K for Commercial
- Have the installer show you the location of the circuit breaker or fuse controlling this appliance and mark it for easy reference.
- Follow all instructions for gas connection and ensure the appliance is connected to the correct type of gas (Natural Gas or Propane). (See pages 17-19).

IMPORTANT GAS SUPPLY WARNING

- DO NOT connect high-pressure gas to the Le Griddle.
- This appliance is designed to operate on low-pressure gas (½ psi) only.
- For natural gas and propane installations, a regulator is not provided.
- For LP gas installations or conversions, use only an approved low-pressure regulator and hose assembly. Approved examples include item number: RONHK or RONHK2.

WARNING: ELECTRICAL GROUNDING

- To reduce the risk of fire, electrical shock, personal injury, or property damage when using this griddle, follow these basic safety precautions:
- The griddle, when installed, must be electrically grounded in accordance with local codes or, in the absence of local codes, with the National Electrical Code, ANSI/NFPA 70, or the Canadian Electrical Code, Part I, CSA C22.1.
- Ensure the griddle is properly installed and grounded by a qualified technician.
- This appliance must be connected to a Ground Fault Circuit Interrupter (GFCI)-protected electrical circuit.
- This griddle is equipped with a three-prong (grounding) plug for protection against electrical shock and must be plugged directly into a properly grounded three-prong outlet. Do not cut or remove the grounding prong from the plug.
- Use only extension cords with a three-prong grounding plug, rated for the electrical load of the appliance, and approved for outdoor use with a “W-A” or equivalent outdoor-use marking.
- To protect against electrical shock, do not immerse the power cord, extension cord, or plug in water or other liquids. Unplug the appliance from the outlet when not in use and before cleaning. Allow the appliance to cool before installing or removing parts.
- Do not use this outdoor cooking appliance if it has been submerged in water. Contact a qualified technician to inspect the appliance before reuse.
- Do not allow the power cord to hang over the edge of a table or contact hot surfaces.
- Do not operate this appliance with a damaged cord or plug, or if the appliance malfunctions or has been damaged in any manner. Contact the manufacturer or an authorized service technician for repair.
- Always disconnect the electrical supply before servicing the appliance.

SAFETY CHECKLIST

(Must be completed before every use)

☐ Gas Odor Check

If you smell gas, do not operate the appliance. Turn all control knobs to the OFF position, shut off the gas supply, and follow the leak-testing procedures outlined in this manual. Contact a qualified technician or gas supplier if a leak is suspected.

☐ Supervision

Ensure you are prepared to remain with the appliance for the entire cooking process. Never leave the appliance unattended while in use.

☐ Clear Cooking Area

Verify that the cooking area is clear of all combustible materials, other than food, that could ignite. Remove any flammable items before lighting the appliance.

☐ Control Knob Operation

Confirm that all control knobs turn freely. If any knob does not operate properly, discontinue use and contact an authorized service provider.

☐ Propane Cylinder Connection (If Applicable)

If using a portable LP cylinder, confirm it is properly connected and has been leak-tested using a soap-and-water solution as described in this manual. Do not proceed until all connections are verified leak-free. (See page 26)

☐ Gas Shut-Off Location

Confirm you know the location of the main gas supply shut-off valve and that it is accessible.

☐ Stability and Installation

Verify the appliance is properly installed, level, and securely supported.

- Built-in models must be securely installed in the cabinet or enclosure.
- Freestanding models must be stable on a flat and properly secured on the cart.
- Counter-top models must be on a stable and flat non-combustible surface.

☐ Wind Conditions

Operate the appliance only in no wind or light wind conditions. Strong or gusting winds blowing toward the rear or sides of the griddle may affect burner performance. If necessary, reposition a freestanding unit so wind enters from the front, or wait until conditions improve. A wind guard accessory may be used with built-in models only.

(Item Numbers: LGUWG & LGWGE).

Natural Gas and L.P. Cylinder Ventilation Requirements

(See Figures 13.2 + 13.3 on page 11)

When Natural Gas or an L.P. Cylinder is used inside an enclosure, the following ventilation guidelines must be followed:

Ventilation Options

- **You must provide either:**

- One completely open side of the enclosure to the outdoors, or a minimum of 4 vent openings (two at the top level and two at the floor level).
- Each opening must provide a minimum of 45 sq. in. of free area.
- Total required ventilation: 180 sq. in. of free area for every 4 feet of cabinet.
- All openings must be equal in size.

Vent Opening Requirements

- **Both Top & Floor Level Vents must be:**

- Located on adjacent enclosure walls and spaced a minimum of 90° apart.
- The top vent opening must be positioned 1" or less below the countertop and end no more than 5" below the countertop level.
- The floor vent openings must be positioned 1" or less above the floor and end no more than 5" above the floor level.
- When using multiple vents, space them so that at least one vent opening is provided for every 4 feet of enclosed cabinet length for adequate airflow.

- ****Additional Notes**

- These ventilation requirements also apply when multiple appliances are installed in the same enclosure.
- Vents must remain open and unobstructed at all times.
- When using multiple vents, space them so that at least one vent opening is provided for every 4 feet of enclosed cabinet length for adequate airflow.

Large Cylinder Requirements

- For L.P. cylinders larger than 20 lb capacity:
 - Provide a minimum of 1 in² per pound of cylinder capacity for top vents.
 - Provide a minimum of ½ in² per pound of cylinder capacity for bottom vents.

Natural Gas and L.P. Cylinder Ventilation Requirements Continued

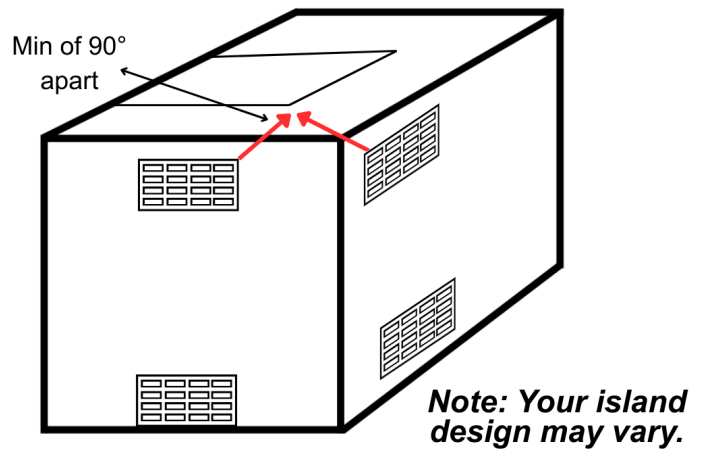
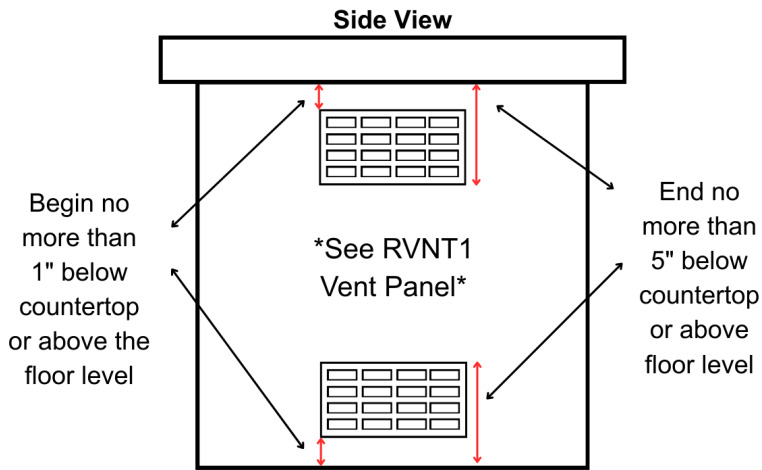

(Figures 13.2 + 13.3)

L.P. Cylinder Requirements

The L.P. gas cylinder must meet all U.S. Department of Transportation (DOT) specifications and be designed specifically for a QCC-1 quick-disconnect system. Failure to comply may result in equipment damage or personal injury.

Installation Requirements

- A pressure regulator must be used.
- This appliance is designed to operate on low-pressure gas ($\frac{1}{2}$ psi) only.
- Use a standard 20 lb. LP cylinder equipped with a QCC-1 connection, along with an approved hose and low-pressure regulator such as the item number: RONHK2.
- The cylinder must have a shut-off valve that terminates in a valve outlet designed for QCC-1 connections.
- The cylinder must include a listed overfill prevention device (OPD).
- The cylinder supply system must be arranged for vapor withdrawal only.
- Ensure the cylinder is equipped with a protective collar to shield the valve.
- Do not store a spare L.P. cylinder under or near the appliance.
- Never fill an L.P. gas cylinder beyond 80% capacity.
- Pressure regulators and hose assemblies must be replaced with approved components purchased from authorized dealers.

EXHAUST HOOD REQUIREMENTS: RESIDENTIAL USE ONLY

For commercial installations, follow local commercial certification or fire department requirements.

OUTDOOR EXHAUST HOOD REQUIREMENTS

- When installing the griddle beneath combustible overhead construction, an outdoor-rated exhaust hood is required. The exhaust hood must be properly sized to safely capture heat, smoke, and grease produced during normal operation.
- Ventilation hood required: 600 CFM (internal blower) or 900 CFM (external blower)
- Hood must fully cover the cooking surface and extend at least 3 inches on all sides
- Maximum distance from cooking surface to hood: 30 inches
- Clean fans and filters regularly; do not allow grease buildup
- Consult a local appliance dealer for a compliant ventilation hood

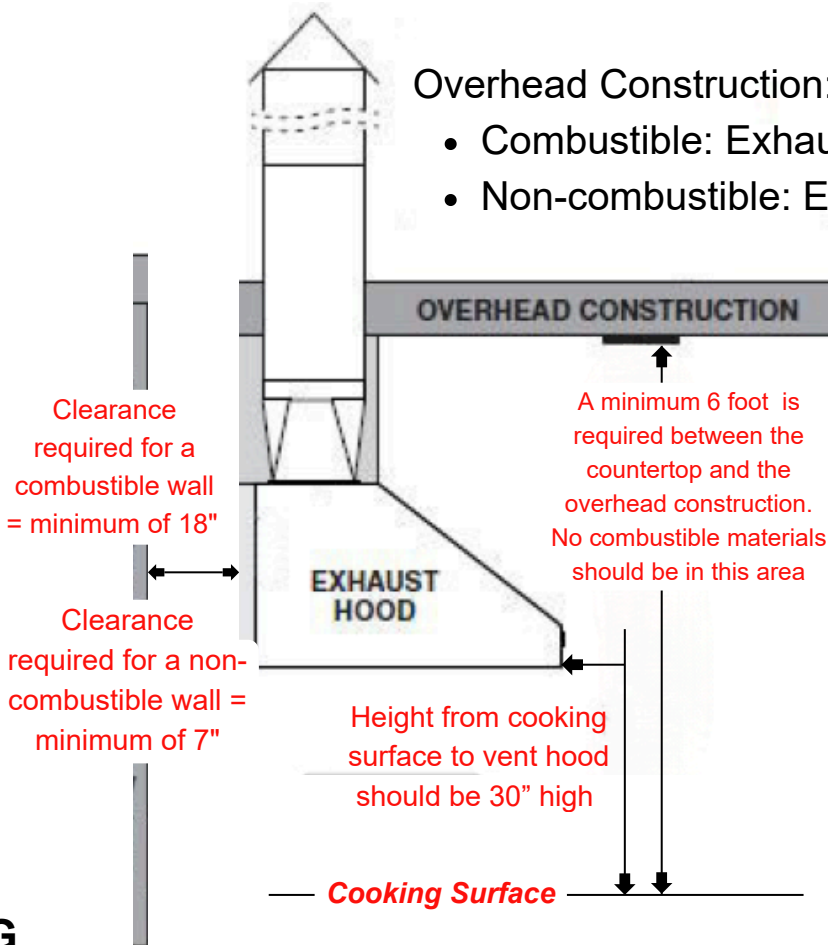

Overhead Construction:

- Combustible: Exhaust hood required
- Non-combustible: Exhaust hood recommended

WARNING

- Never leave the appliance unattended
- Keep a visible, accessible class ABC fire extinguisher nearby
- In case of a griddle-top fire, avoid operating the ventilation system; do not reach through flames
- Maintain a minimum 5 ft vertical clearance to overhead structures. No combustible material should be in that area. (See image above).

INDOOR GAS SUPPLY REQUIREMENTS

- Route the gas supply line away from heat sources, sharp edges, and abrasive surfaces. Use as few bends as possible.
- The gas connection must remain accessible after installation.
- A manual shut-off valve is required and must be easily accessible to allow the gas supply to be quickly turned off.

INDOOR EXHAUST HOOD REQUIREMENTS

- **Residential instructions only. For commercial installations, follow local commercial certification or fire department requirements.**
- All heat, smoke, grease vapor, and combustion products must be captured and exhausted from above the cooking surface.
- A ducted powered exhaust hood vented to the exterior is required
- Recirculating (ductless) hoods are not permitted
- Ventilation hood required: 600 CFM (internal blower) or 900 CFM (external blower)
- Hood must fully cover the cooking surface and extend at least 3 inches on all sides
- Maximum distance from cooking surface to hood: 30 inches
- Make-up air may be required for high-CFM exhaust systems
- Clean fans and filters regularly; do not allow grease buildup
- Consult a local appliance dealer for a compliant ventilation hood

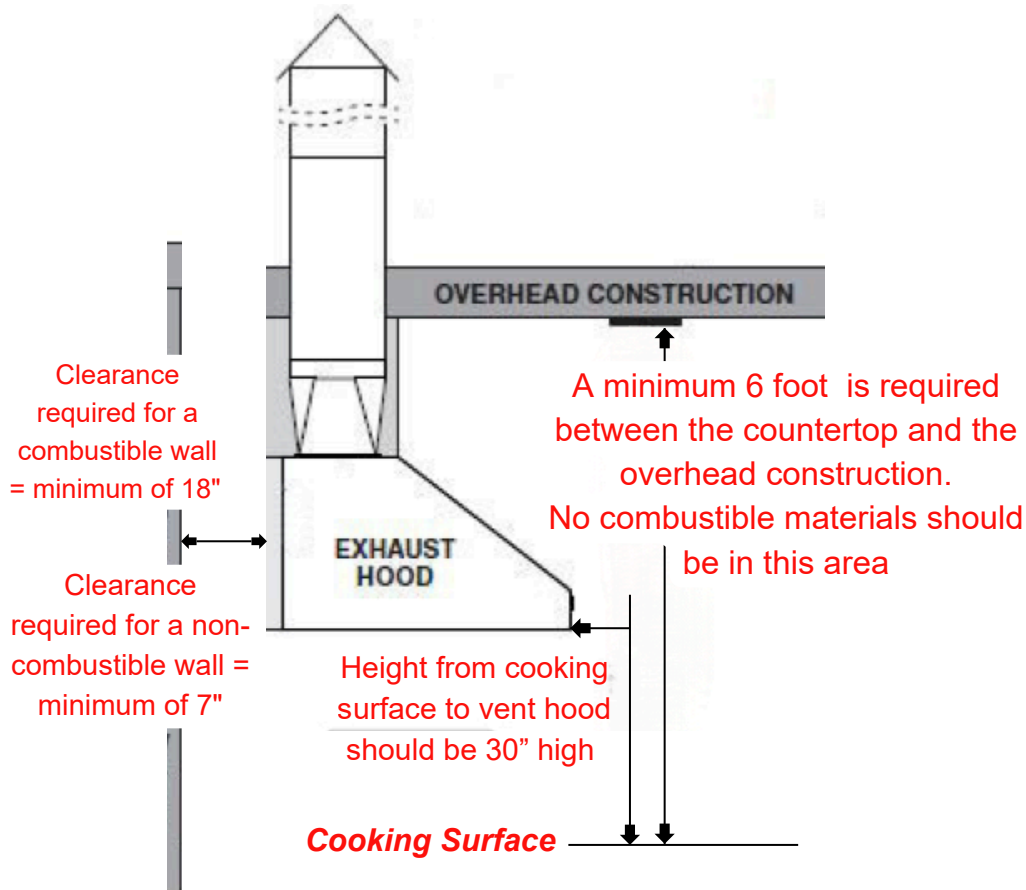

INDOOR KITCHEN INSTALLATION

This appliance is certified to ANSI Z83.11 / CSA 1.8 and is approved for indoor installation only when installed in accordance with these instructions and all applicable local codes. *These instructions are for residential use only. For commercial installations, follow local commercial certification or fire department requirements.*

When installed in an indoor kitchen, the griddle must be built into non-combustible materials. Combustible materials are prohibited, even when used with a liner.

Recommended non-combustible materials include:

- Stainless steel
- Stone
- Concrete
- Tile

Ventilation is required in the cabinet, specifically where the gas connection to the griddle is located. Provision must be made for the evacuation of unburned gases that may result from a leak. Under no circumstances should the cabinet under the griddle and/or housing the gas connection be airtight. The enclosure must be passively ventilated in accordance with the manufacturer's installation requirements and applicable IRC/IFGC safety provisions to prevent heat and gas accumulation. The installation must comply with NFPA 54 (National Fuel Gas Code) and NFPA 96 (Ventilation Control and Fire Protection of Commercial Cooking Operations). The installer must ensure that the installation complies with the specific regulations of the local authorities (AHJ – Authority Having Jurisdiction) and (IMC-International Mechanical Code).

Ventilation is required in the cabinet, particularly in the area housing the gas connection. Both low-level (air intake) and high-level (exhaust) ventilation openings are required.

Low-Level Ventilation (Air Intake)

- Minimum surface area: 12 sq in (75 cm²)
- Located less than 3.9 in (100 mm) from the bottom of the cabinet
- Located on the lower front, lower side, or rear
- Never directly under a burner

High-Level Ventilation (Exhaust)

- Minimum surface area: 12 sq in (75 cm²)
- Located less than 3.9 in (100 mm) from the top
- Located at the rear or upper side
- Never directed towards a sensitive combustible material

INDOOR EXHAUST HOOD REQUIREMENTS CONTINUED

- Install smoke, heat, and carbon monoxide detectors in the cooking area
- Never leave the appliance unattended
- Never attempt to extinguish a grease fire with water or any other liquid.
- Keep a fire extinguisher ready at all times:
 - Class ABC for residential
 - Class K for Commercial
- In case of a griddle-top fire, avoid operating the ventilation system; do not reach through flames
- Recommended griddle height: 33" to 37" inches from the finished floor for a comfortable working position
- Failure to follow these instructions may result in improper operation, fire hazard, or unsafe indoor air conditions
- When installed indoors, the enclosure must be constructed entirely of non-combustible materials
- Proper hood design and airflow are critical to safe operation and indoor air quality.

INSTALLATION STEPS

GAS CONNECTIONS

1. Before installation, follow these steps to connect the appliance to the gas supply.
Note: It is recommended that two people move the griddle to prevent injury or scratching the unit.

2. Take your Le Griddle Body (Box 1 of 2) out of the packaging with care and remove the grease trays from the unit.

Pro Series

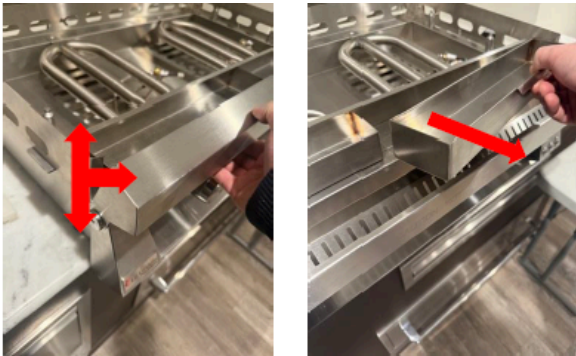

Commercial Series



CAUTION: NEVER HANDLE A HOT GREASE TRAY

3. Make sure all the knobs are in the OFF position. The line on your knob should be pointed upwards.

4. Flip the unit upside down and put it on a soft flat surface to prevent scratches, as shown in (Fig. 1a/b). You can access the gas connection of the appliance easily (Fig. 2) to make the connection safely.



Pro Series

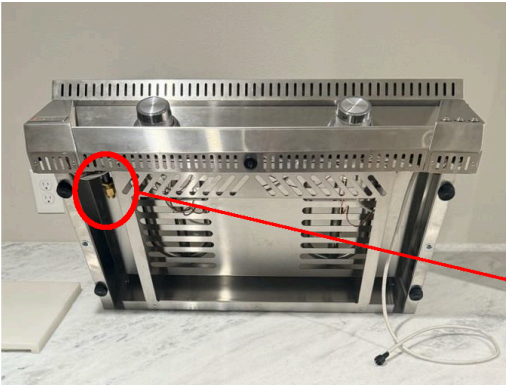

Fig. 1a

Fig. 2
Gas Connection



Commercial Series

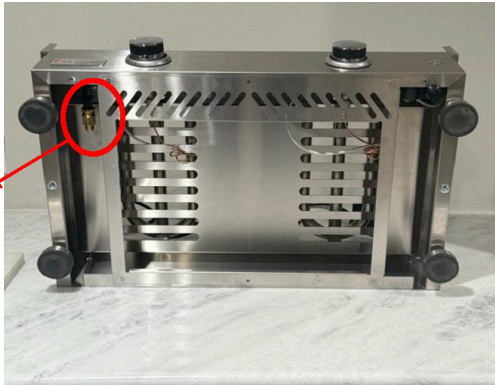
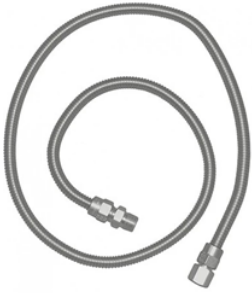

Fig. 1b

5. The next steps are determined by the specific gas type being used. Please be sure to follow the correct steps. (For NG see pages 17-18, for LP see pages 18-19).

FOR NATURAL GAS INSTALLATION, FOLLOW THESE DIRECTIONS.

1. Make sure you have completed steps 1-4 of the gas connections steps on page 16.
2. For use with Natural Gas, we recommend using a 3/8" stainless steel flex line (not included) to connect to your low-pressure natural gas source (Fig. 3). We strongly recommend the stainless steel flex lines SSFLEX6436 or SSFLEX6448. These griddles use a 7" water column / .25 psi.



- Item Number: SSFLEX6436**
3/8" Stainless Steel Flex Hose - 36" Long
- Item Number: SSFLEX6448**
3/8" Stainless Steel Flex Hose - 48" Long

Fig. 3

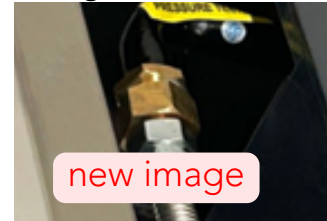

3. Remove the attached fittings on the end of the flex lines as they are not needed for this install.

Never connect two flex lines to each other.

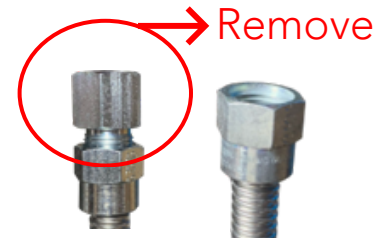

4. Connect the flex line to the unit:

- a. Connect the 3/8" female flare end of the flex line to the 3/8" male flare connection of the unit and screw in a clockwise rotation by hand until it stops (Fig. 4).
- b. Use the 7/8" wrench on the griddle gas connection (Fig. 5).
- c. Use the 3/4" wrench on the flex line female connection (Fig. 6).
- d. Hold the 7/8" wrench so the griddle gas connection fitting cannot move when you tighten the female flex line connection with a 3/4" wrench (Fig. 7).

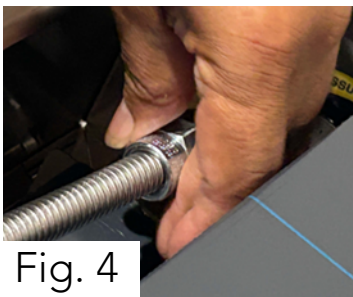

Fig. 4



Fig. 5



Fig. 6



Fig. 7

Note: Do NOT use pipe sealant, tape, or any sealing compounds.
These are not required for flare connections.

NATURAL GAS INSTALLATION DIRECTIONS CONTINUED

5. Make sure your knobs are in the off position. Connect the flex line or hose to the low-pressure natural gas source (NG). Check that the hose is in good condition and replace it if it looks cracked or damaged. The hose should not be twisted or pulled and should not come into contact with hot parts of the appliance. Turn on the gas supply and double-check if there are any leaks by applying soapy water to the connection (Fig. 8). **IF YOU SEE ANY BUBBLES THERE IS A LEAK, TIGHTEN THE CONNECTION FURTHER. IF NOT RESOLVED, CONTACT YOUR DEALER AND DO NOT INSTALL THE UNIT.**



Fig. 8



DANGER:
NEVER OPERATE A
GAS APPLIANCE
THAT HAS A LEAK

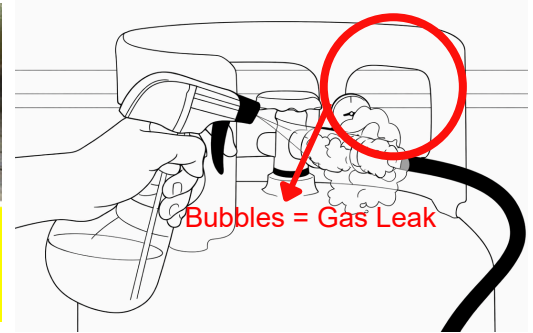

FOR PROPANE INSTALLATION, FOLLOW THESE DIRECTIONS

1. Make sure you have completed steps 1-4 of the gas connections steps on page 16.
2. Connect the propane hose kit (Fig. 9) to the unit:
 - a. Attach the 3/8" Female flare end to the 3/8" Male flare connection (Fig. 10) by screwing/rotating the brass fitting in a clockwise rotation by hand up it stops (Fig. 11).



Fig. 9
RONHK / RONHK2

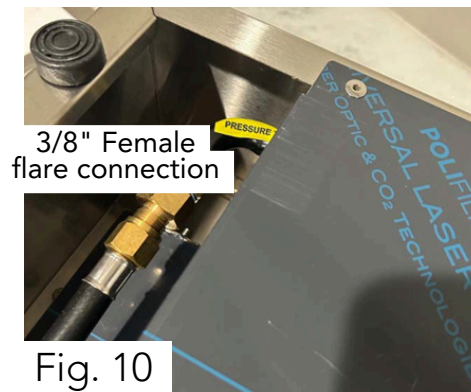

Fig. 10



Fig. 11

PROPANE INSTALLATION DIRECTIONS CONTINUED

3. Tighten the connection carefully by using 2 properly-sized wrenches (7/8" on the male gas connection of the unit and 3/4" on the female connection of the hose).
 - a. Use the 7/8" wrench on the gas unit connection (Fig.12).
 - b. Use the 3/4" wrench on the gas propane hose female connection (Fig. 13).
 - c. Hold the 7/8" wrench so the gas unit connection fitting cannot move when you tighten the Female gas hose connection with 3/4" wrench (Fig. 14).



Fig. 12



Fig. 13



Fig. 14

Note: Do NOT use pipe sealant, tape, or any sealing compounds.
These are not required for flare connections.

4. Make sure your knobs are in the off position and your propane tank is shut off. Connect the propane hose to the propane tank (LP). Turn on your propane tank while the griddle is upside down to test the gas connections for leaks with soapy water (Fig. 15). IF YOU SEE ANY BUBBLES THEN THERE IS A LEAK, TIGHTEN THE CONNECTION FURTHER. IF NOT RESOLVED, CONTACT YOUR DEALER AND DO NOT INSTALL THE UNIT.



Fig. 15

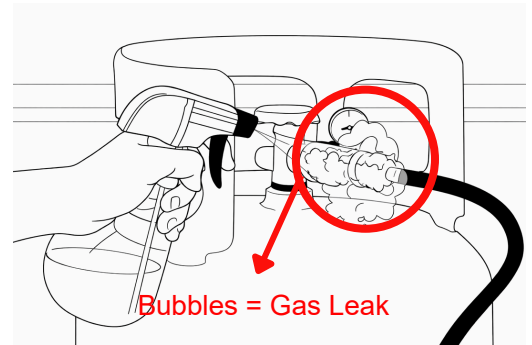

OUTDOOR KITCHEN INSTALLATION

- Before installing the appliance into an island cut-out, verify that the opening is not larger than the outside frame of the unit. The appliance must rest securely on the frame lip. (See cut-out recommendations on page 24)
- Secure the griddle to the cabinet following the instructions on page 21 “*How to Secure the Griddle to a Cabinet.*”
- Route the gas supply line away from heat sources, sharp edges, and abrasive surfaces, using as few bends as possible. The gas connection must remain accessible after installation and include a manual shut-off valve.
- Adequate Ventilation: The cabinet structure must allow unrestricted airflow around the griddle and gas supply. Proper ventilation is required for combustion, heat dissipation, and to prevent gas buildup in the event of a leak. Approved ventilation openings (such as RVNT1 vents by RCS Gas Grills) are required every 4 feet. See pages 14-19 for outdoor ventilation requirements
- Recommended griddle height is 33 to 37 inches from the ground for a comfortable working position.
- When installed in an outdoor kitchen, the enclosure must be constructed of non-combustible materials or incorporate an approved Le Griddle insulated liner.
- Maintain access to all service components, including the gas piping or hose, regulator, gas cylinder, and shut-off valves.
- Do not grout or apply silicone around the griddle.

PRO SERIES

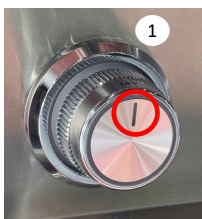

1
Ensure the knobs are on OFF position.



2
Remove the feet and connect the gas line (see p.11,12,13 how to connect the gas)



3
Install the body into the cabinet and remove the grease trays (see p.10)

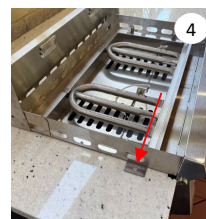

4
Secure the body to the counter top (see p.21)

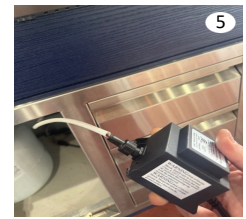

5
Connect the transformer and plug the power supply outlet (see p.34)



6
Install the cooking plate (box 2 of 2) seat on the standoffs inside the body (be two people)

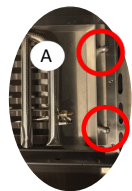

A
Seat the plate on the standoffs located on each side of the body

Place the plate and ensure a distance between the edges and the body

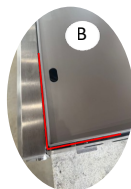

7
Install the grease trays and close the tilting front panel.



CONTINUE TO PAGE 21 FOR PHOTO REFERENCES.

COMMERCIAL SERIES



1
Ensure the knobs are on OFF position and connect to the gas line as shown p.11,12,13



2
Install the body into the cabinet, open the top banner and remove the grease trays (see p.10)

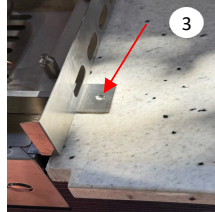

3
Secure the body to the counter top (see p.XX).



4
Install the cooking plate (box 2 of 2) seat on the standoffs inside the body (be two people)

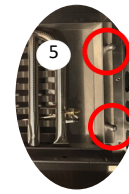

5
Seat the plate on the standoffs located on each side of the body

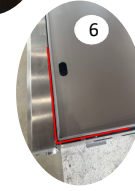

6
Place the plate and ensure a distance between the edges and the body



7
Install the grease trays and close the front panel.



8
READY

COUNTER-TOP INSTALLATION

1. When the body is installed in the cut-out, mark the spot through the hole in the support with a pencil or a marker.
2. Drill a Ø5 hole and install the anchor (**Anchor NOT provided**).
3. Secure using a #8 screw suitable for countertop material and thickness. (**Screw NOT Provided**).



By indicated us the characteristics of your countertop we can provide the corresponding screws for free.



Pro Series with lid



Pro Series without lid



Commercial Series

COUNTER-TOP INSTALLATION

Adjust the height of the feet by screwing or unscrewing to ensure that the gas hose or flex line passes between the counter-top and the bottom of the griddle.

BE CAREFUL THAT THE GAS HOSE IS NEVER CRUSHED.

We recommend passing the gas hose or flex line between the two feet to exit out the side of the unit. Install the Griddle on a flat surface coated with an inflammable material (tiles, firebrick, etc.).

- The distance between the griddle and a combustible wall must be at least 24".
- The distance between the griddle and a non-combustible wall must be at least 12".

PRO SERIES



1 Place the body on a flat surface



2 Position the back of the front panel against the counter top.



3 Pass the regulator hose between the legs of the appliance, and adjust the height by unscrewing the feet.



4 Do the same on the other side to ensure the overall flatness and run the power cord to the transformer between the legs.



6 Open the top panel as shown on page 16 and install the plate onto the body (two people are recommended for this step).

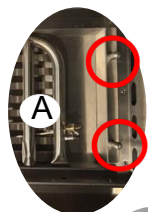

A Seat the plate on the standoffs located on each side of the Body.

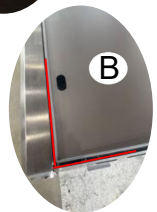

B Place the plate and ensure a distance between the edges and the body.



7 Reinstall the grease trays, close the top panel.



READY

COMMERCIAL SERIES



1 Place the body on a flat surface.



2 Adjust the level of the unit by unscrewing the adjustable feet.

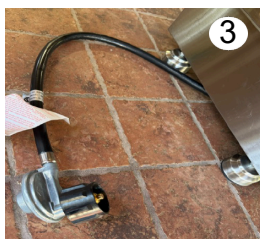

3 Pass the regulator hose between the legs of the Appliance.



4 Open the top panel as shown on page 10 and install the plate onto the body (two people are recommended for this step).



A Seat the plate on the standoffs located on each side of the Body.

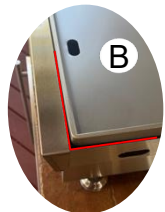

B Place the plate and ensure a distance between the edges and the body.



5 Reinstall the grease trays, then the top panel.



READY

CART INSTALLATION

Make sure to use the cart on a flat surface and ensure that the entire assembly is stable. The distance between the griddle and a combustible wall must be at least 24". The distance between the griddle and a non-combustible wall must be at least 12".

PRO SERIES

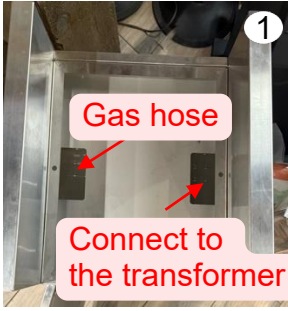

Remove the feet and connect the gas line. (See page 16 - 19).



Place the body into the cart.



Ensure the back of the front panel applied against the cart Support.



On each side from below, Secure the body to the cart thanks to the screw provided with the cart.



Connect the griddle to the transformer and then plug to the extension cord 3 plugs with ground (see page 32).



Install the cooking plate (box 2 of 2) seat on the standoffs inside the body (be two people)

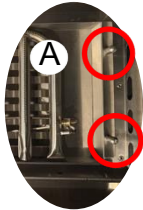

Seat the plate on the standoffs located on each side of the body

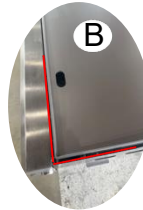

Place the plate and ensure a distance between the edges and the body



Install the grease trays and close the tilting front panel.

COMMERCIAL SERIES

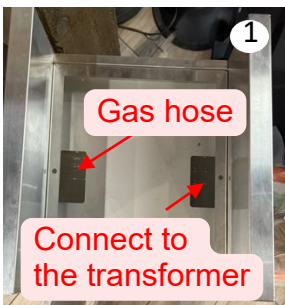

Remove the feet and connect the gas line (see page 16-19. How to connect the gas).



Place the body into the cart.



On each side from below, Secure the body to the cart thanks to the screw provided with the cart.



Install the cooking plate (box 2 of 2) seat on the standoffs inside the body (be two people)

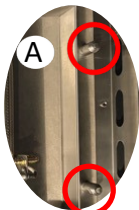

Seat the plate on the standoffs located on each side of the body

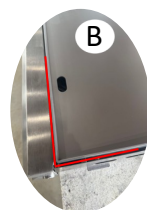

Place the plate and ensure a distance between the edges and the body



Install the grease trays and the front panel.

Technical Description

Characteristics

- Stainless steel frame, cooking plate (food-contact certified), and burners
- Thermocouples with automatic gas shut-off
- Wind-resistant flame protection (Normal wind)
- Electronic ignition (120V - 12V Transformer for Pro Series or the AA/AAA battery included with the Commercial Series.
- Compatible with LP or natural gas (conversion may be required)
- Three-sided trim
- Removable grease tray for liquid and waste collection
- Optional protective cover

Reference	Body Size in Inches	Gas	Weight	BTU	Orifices	Cooking Surface	Cooking Material	Gas Connection
	W x D x H							
OML40P	16 1/2 x 18 3/4 x 10	Propane or Natural Gas	52lb	1 X 9000	0,9 (LPG) 1.40 (NG)	16 x 16 1/2	Stainless steel + Aluminium + Cast iron	3/8 FLARE
OML75P OML75C	30 x 18 3/4 x 10	Propane or Natural Gas	98lb	2 X 9000	0,9 (LPG) 1.40 (NG)	29 x 16 1/2	Stainless steel + Aluminium + Cast iron	3/8 FLARE
OML105P OML105C	41 x 18 3/4 x 10	Propane or Natural Gas	120lb	3 X 9000	0,9 (LPG) 1.40 (NG)	41 1/4 x 16 1/2	Stainless steel + Aluminium + Cast iron	3/8 FLARE

CUTOUT DIMENSIONS		A	B	C
Item #	Description	Width	Length	Depth
OML40	16" Le Griddle (1 burner)	14 3/4"	16 3/4"	5 3/4"
GFLINER40	16" Le Griddle Liner	17 1/2"	17 1/2"	7 1/4"
OML75	30" Le Griddle (2 burners)	28 3/4"	16 3/4"	5 3/4"
GFLINER75	30" Le Griddle Liner	31 1/2"	17 1/2"	7 1/4"
OML105	41" Le Griddle (3 burners)	40 1/2"	16 3/4"	5 3/4"
GFLINER105	41" Le Griddle Liner	43"	17 1/2"	7 1/4"

***If installing with lid and there is a back wall, the clearance between the open lid and back-wall must be a minimum of 7".**

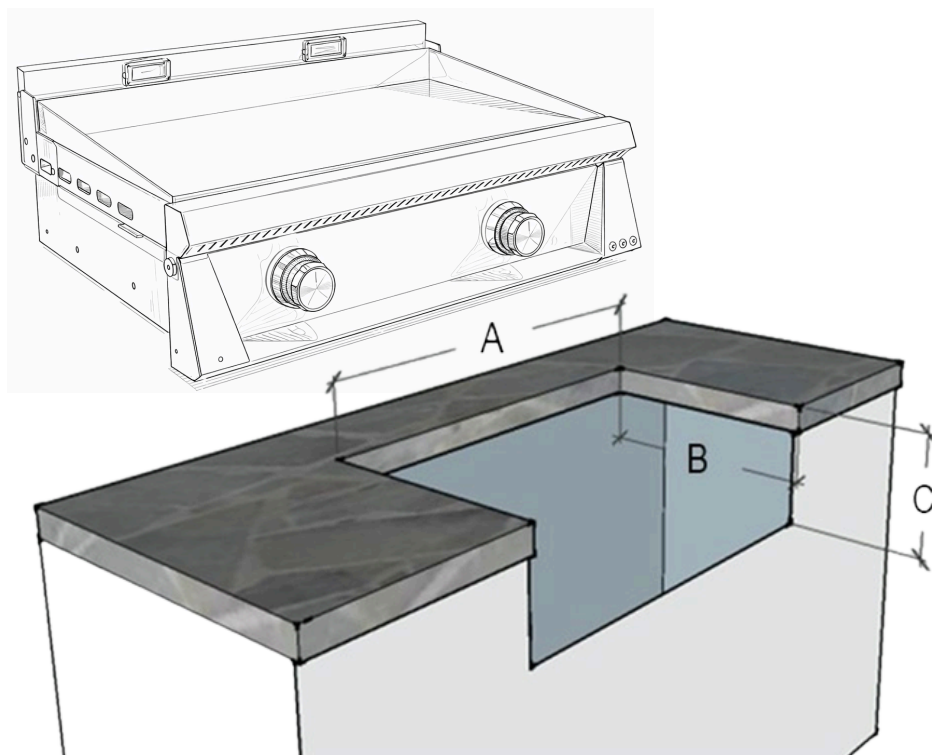

INITIAL USE / START UP

Before operating your griddle for the first time, complete the following checks to ensure safe and proper operation:

- Remove all packaging, protective covers, tie-downs, films, and adhesive residue from the appliance.
- Verify the correct fuel type is connected and securely installed.
- Have a qualified plumber or licensed professional perform a leak test on all gas supply connections (see page 18-19).
- Confirm any required electrical connections are properly installed.
- Clean the cooking plate with warm water and mild soap; rinse and dry thoroughly. Repeat until no residue remains.
- Open the lid, if equipped. Proceed with the instructions below specific to your model.

PRO SERIES IGNITION

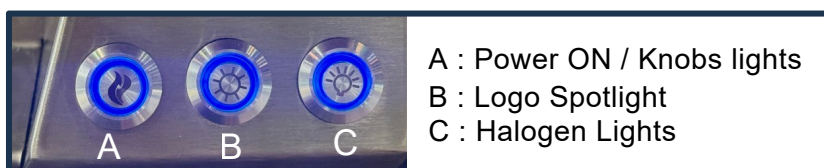

- Push in the power/shut-off button identified by the flames logo. The blue LED lights around the knobs will indicate that the griddle is energized.
- Push in the knob and turn to the left to ignite the griddle. Keep the knob pushed in until you see the flames light on and stabilize. The flame is visible through the side of the appliance.

DO NOT HESITATE TO PUSH STRONGLY THE KNOB TO ENSURE THE GAS VALVE DEPRESSED CORRECTLY TO ACTIVATE THE THERMOCOUPLE SAFETY SYSTEM.



- Keep the knob depressed for 5 to 10 seconds to trigger the thermocouple system.
- Then release the knob and allow the burner to heat the plate to the desired cooking temperature.
- After approximately 15 minutes on high, your Le Griddle is now ready to begin cooking.

COMMERCIAL SERIES IGNITION

- Press and hold the ignition button while rotating the control knob counter-clockwise until the arrow is in the 9 o'clock position until it lights the burner. The flame is visible through the side of the appliance.
- Keep the knob depressed for 5 -10 seconds to trigger the thermocouple system.
- Then release the knob and allow the burner to heat the plate to the desired cooking temperature.
- After approximately 15 minutes on high, your Le Griddle is now ready to begin cooking.

INITIAL USE / START - UP CONTINUED (BOTH PRO AND COMMERCIAL)

- Surface temperatures and cooking times will vary depending on the type of gas used (Natural or LP), the ambient temperature while cooking outdoors, wind, and other factors.
- Preheat time: 15 min for an outside temperature of 70°F. Increase or reduce this time by 5 minutes for every 15°F outside temperature. Medium is the preferred temperature for cooking most foods.
- Do not preheat with the optional lid closed.
- Do not let the griddle heat up without any food on it for more than 30 minutes.
- Do not use a laser gun to measure the temperature; the stainless steel reflects the beam, preventing an accurate reading. For surface temperature testing, use a contact thermometer only.

Note:

- The griddle may give off a little smoke or odor the first time it is used; this is perfectly normal.
- Each time the griddle is used, push and turn the knob to the big flame position and hold it down for 2 seconds to allow air to escape, then push the ignition button and hold for 5 more seconds, then release the knob.
- To view the flame, look through the side of the appliance.
- Over time, you will be able to gauge the best cooking temperature and time according to the thickness and texture of food and adapt it to your taste. For cooking and cleaning videos and tips, go to LeGriddle.com
- Do not cut food directly on the Griddle cooking surface to avoid causing deep scratches.
- Do not leave kitchen utensils on the Griddle, such as cutlery, wooden spoons, plastic utensils, etc.
- Do not overheat the griddle when cooking, as this could blacken the plate and make cleaning difficult.
- The Griddle can also be used to keep food warm after cooking.

CLEANING AND MAINTENANCE SAFETY

AT THE START OF EACH SEASON

At the beginning of each new griddling season, perform the following inspections:

- Inspect burners, venturi tubes, orifices, and valves for obstructions. Spiders and insects can nest in these areas, restricting airflow and potentially causing damage, fire, or personal injury.
- Check all gas hoses and fittings for damage, abrasion, cracking, or excessive wear. Replace any damaged components before operating the appliance.

SHUTTING DOWN

- After each use, switch off your appliance, turning the knobs clockwise to the OFF position.
- Shut the gas bottle or gas supply valve off.

WHEN CHANGING THE GAS TANK

- LP cylinder must always be changed with the control knobs in the off position, and the propane tank valve closed.
- LP cylinder must be changed in a well-ventilated place, away from any heat sources (cigarettes, electrical appliances, etc.).
- Check for leaks using a soapy water solution each time the LP cylinder is replaced or reconnected. If there are any bubbles forming around the gauge and connector, this means there is a gas leak. Any leaks must be corrected immediately.

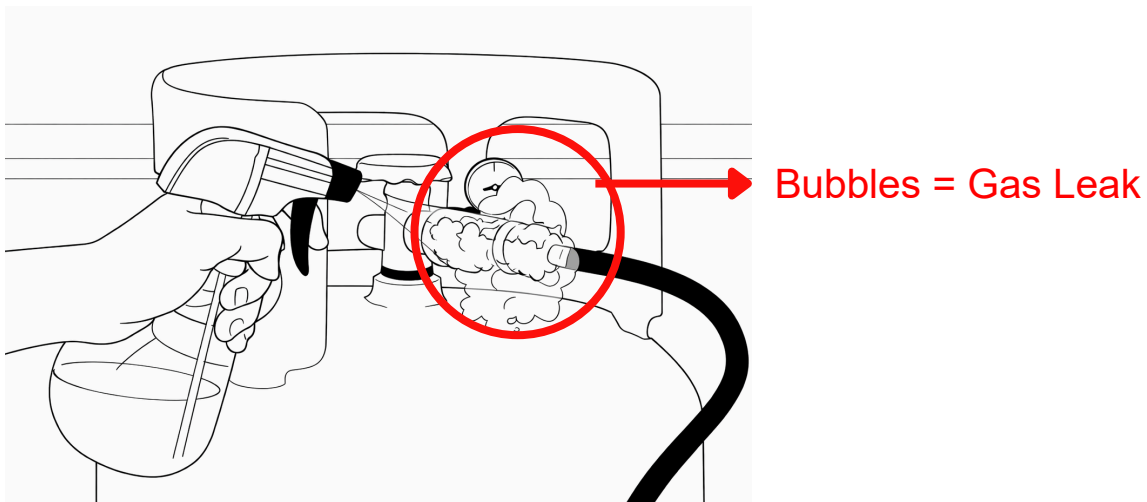

CLEANING AND MAINTENANCE SAFETY

- Keep the griddle area clear and free from combustible materials, gasoline, and other flammable vapors or liquids.
- In the event of a spill or boil-over, turn off the burner and allow the griddle to cool completely before cleaning.
- To avoid the risk of electrical shock, disconnect the electrical supply before servicing the griddle.

STAINLESS STEEL CARE AND MAINTENANCE

Le Griddle stainless steel products are known for their attractive appearance. This is achieved by selecting premium-grade stainless steel and applying precise workmanship. To maintain this appearance over the life of the griddle, follow these guidelines:

- After each use, wipe down the exterior surfaces to remove grease and splatter.
- Follow the recommended cleaning instructions to keep the griddle plate clean and ready for use.
- Use a commercially available stainless steel cleaner to clean and polish exterior surfaces.
- Do not use metallic abrasives. Always scrub in the direction of the grain.
- Some household cleaning products (even those rated for high heat) are not suitable for stainless steel. Always read the product label before use.
- Start with the mildest cleaning solution and increase only as needed, scrubbing in the direction of the grain.
- Grease particles can settle into the grain and bake onto the surface, sometimes giving the appearance of rust. To remove these deposits, use a fine- to medium-grit non-metallic abrasive pad (such as Scotch-Brite®) in combination with a stainless steel cleaner. Always wipe in the direction of the grain.
- **Important:** Cleaning solutions designed for concrete or masonry are highly corrosive and will damage stainless steel. Ensure your Le Griddle is protected whenever such chemicals are used nearby.

CLEANING AND MAINTENANCE SAFETY CONTINUED

Drip Tray Cleaning

The drip tray should be cleaned after each use.

1. Allow the griddle to cool completely.
2. Tilt the front panel forward and pull the tray outwards.
3. Wipe clean with a paper towel or place it in a dishwasher for thorough cleaning.
4. Also available are aluminum foil grease tray liners. Item number: LGTRAY20

Special Note for Poolside and Coastal Installations

The 304 stainless steel used in Le Griddle products is highly rust-resistant. However, chlorine from swimming pools and salt in coastal air can cause surface rust or pitting if not properly maintained.

To minimize corrosion in these environments:

- Regularly wipe exterior surfaces with a damp cloth in the direction of the grain. (microfiber cloths are highly effective).
- Allow all surfaces to dry completely before installing the cover. Never cover a hot or damp griddle.
- In harsh environments, apply a rust inhibitor that leaves a microscopic protective layer on the lid and body. (Do not apply to the cooking surface).
- For seasonal storage, ensure the griddle is clean and dry, apply a rust inhibitor to the body and lid, then cover and secure the cover to limit exposure to moist air.

The Le Griddle **Limited Lifetime Warranty** provides protection against rust-through of parts that render the product inoperable. This warranty does not cover occasional surface rust or staining caused by environmental conditions.

After First Use

- After your first use, certain areas of the griddle may discolor due to the intense heat produced by the burners. This discoloration is normal, permanent, and cannot be cleaned off.
- For light to heavy food stains on exterior stainless steel surfaces, many commercially available stainless steel cleaners may be used as directed.

CLEANING AND MAINTENANCE SAFETY CONTINUED

Griddle Plate Cleaning

- Use protective, heat-resistant gloves when cleaning the griddle. For Example, Le Griddle Gloves Item Number: LGG
- While the griddle plate is still hot, carefully pour ice onto the surface to loosen stuck-on food.
- Keep your hands and body away from rising steam to avoid burns.
- Scrape food residue toward the drip tray using a spatula or scraper. Recommended tools: the Le Griddle Scraper Spatula (Item No. LGSQS), Angled Scraper (Item No. LGAS), or Bench Scraper (Item No. LGBS).
- Brush the cooking surface using a scouring pad, starting with smooth, light strokes and gradually increasing pressure. Work consistently from left to right, avoiding circular motions. For best results, we recommend using the Le Griddle Cleaning Set (LGCLEAN).
- Allow the drip tray to cool, then remove and empty it.
- Wash the drip tray with warm, soapy water or place it in the dishwasher.
- **IMPORTANT-** Never flood a hot griddle plate with cold water or ice. Sudden thermal shock can promote warping and may cause cracking over time.
- **IMPORTANT-** Place the stainless steel *optional* cover (lid) over the cooking surface only after the unit has cooled completely.

The Frame (Outer body panels, control panel, cart structure, and any non-cooking stainless steel or structural components.)

- Always allow the griddle plate to cool completely before cleaning the frame to avoid burns. Clean using a sponge soaked in warm water and mild detergent. NEVER use abrasive pads, steel wool, or wire brushes on the frame. Wipe in the direction of the grain.

The Cooking Surface (Stainless Steel Griddle Plate)

The cooking surface is easiest to clean when the griddle is slightly warm. Exercise caution to avoid burns.

- The stainless steel plate is shiny when new.
- Over time, utensil use will cause light scratching and dulling. This is normal. As the surface ages, scratches will blend, creating a brushed, seasoned appearance.
- After repeated use, grease residue may appear on the hot plate. This is normal and does not indicate damage.

CLEANING AND MAINTENANCE SAFETY CONTINUED

Removing Grease Residue

- Pour a small amount of water onto the hot plate or apply ice cubes to loosen residue. We recommended the Le Griddle Squeeze Bottle (Item No. LGBBT).
- Scrape loosened residue toward the drip tray using a spatula or scraper.
- Residue may detach on its own during use; this is normal and does not damage the plate.
- Pour additional water onto the plate and soak the remaining residue with a wet sponge or ice cubes.
- Push water and residue into the drip tray using a rigid spatula or scraper.
- Finish cleaning with a non-metallic scouring pad, followed by a soft sponge.
 - We recommend the Le Griddle Cleaning Kit (Item No. LGCLEAN).

Odors, Flavor Transfer & Corrosion Prevention

- To remove odors or strong flavors, on a **COLD COOKING PLATE ONLY**, pour a small amount of vinegar or citrus juice onto the plate and wipe it clean.
- Clean the cooking surface promptly after preparing salty foods to reduce corrosion risk.
- Do NOT use chlorine-based cleaning products, as they can corrode stainless steel.

Burners

- Periodically inspect burner flame ports for debris.
- If blocked, clean using a stiff-bristle brush.
- Clean the burners and burner base thoroughly before reuse.
- Do NOT use metal objects to clean orifices; this may damage components or alter burner performance.

Thermocouple

If the griddle will not remain lit after ignition, the thermocouple probe may be dirty. To clean the thermocouple:

- Allow the griddle to cool completely.
- Remove the cooking plate (two people recommended due to weight).
- Clean the thermocouple probe with a dry, non-metallic abrasive pad.
 - Make sure to maintain the distance between the probe and burner.
- Reinstall the cooking plate before operating the griddle.

STORAGE

Store your Griddle in a dry, sheltered place where it is not at risk of damage. The optional protective cover must only be used when the Le Griddle is cool.

Electrical Connection Location

120 Volt, 60H, 12 Amp

The griddle comes with an AC transformer 120V/12V 60VA connected to a 6-foot electric cord with 3 plugs and grounding. Ensure to connect to a compliant outdoor plug or outdoor extension cord when using outside.

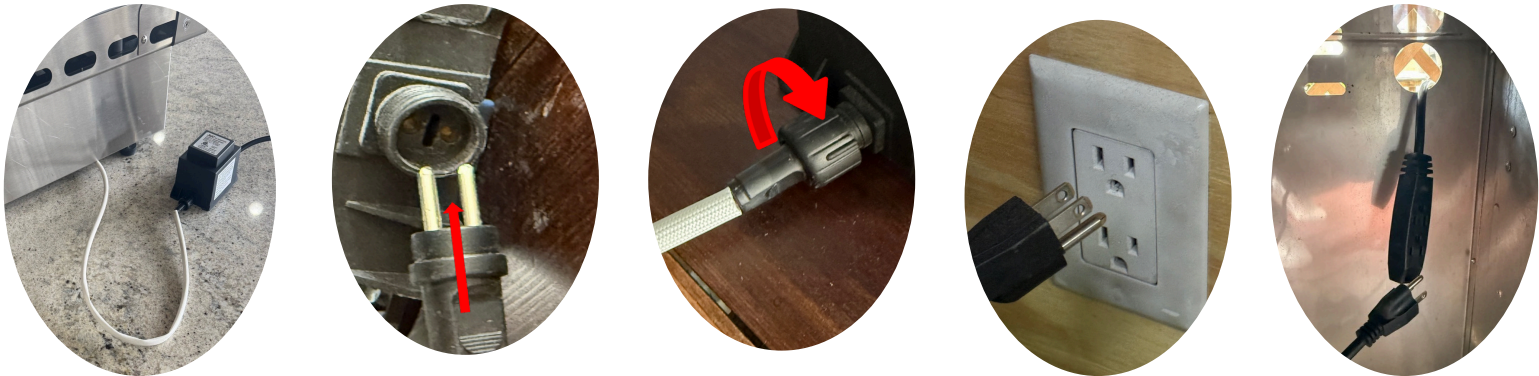

COMMERCIAL UNIT IGNITER BATTERY REPLACEMENT

Included with your commercial unit is a battery:

- GFBATAAA(1.5V) for 2 burners Commercial griddle OML75C3 & OML75C6
- GFBATAA (1.5V) for 3 burners Commercial griddle OML105C3 & OML105C6



The battery is in the ignition box located below the unit.

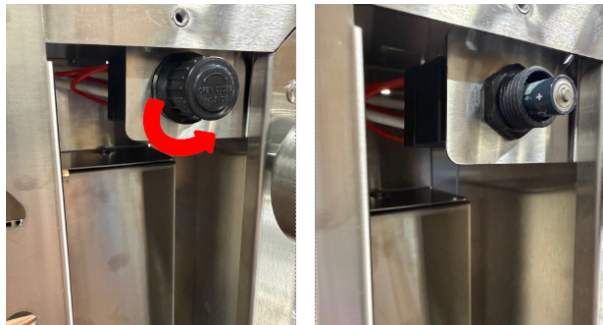

Unscrew the cap and remove the battery then install the new one in the same way and screw the cap.

LOGO SPOTLIGHT SETTING

You can adjust the orientation of the logo projected onto the ground by manually rotating the lens of the logo projector located below the griddle.

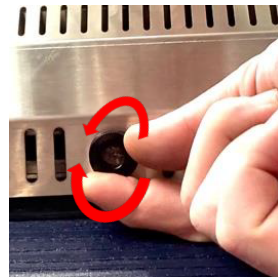
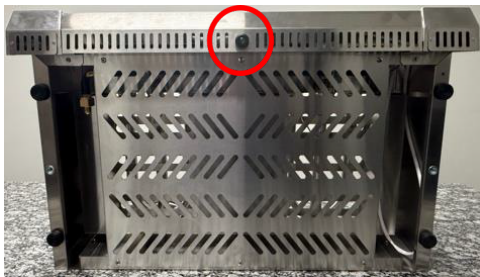
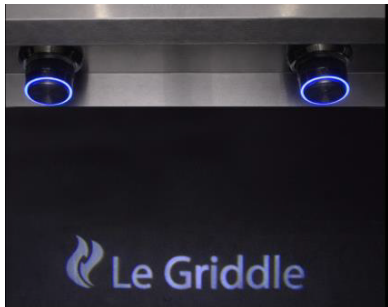

HOW TO CONVERT YOUR GRIDDLE FROM NATURAL GAS TO LIQUID PROPANE

STEP 1: CHANGE THE ORIFICE

- a. Turn your griddle knobs to the off position and disconnect your griddle from any gas source.
- b. Remove the griddle plate by lifting straight up. We suggest two people as it is VERY heavy.
- c. Follow the steps below ↓

PRO SERIES & COMMERCIAL



1
Phillips screw driver to remove the screw from the top of the burner.



2
Remove the screw under the burner



3
Remove the burner



4
Place the burner on the side to access to the gas valve orifice



5
Use the wrench provided to change the Natural Gas orifice (1.4) by the LP Gas orifice (0.9)



6
Reinstall the burner carefully and tighten the 2 screws on top and below the burner

STEP 2: ADJUST THE HEIGHT OF THE LOW FLAME (HI flame do not require a setting)

PRO SERIES



Light on your griddle Follow instructions on Page 24 and place the knob on the low position



Remove the knob by pulling gently



Remove the SLOTTED screws circled in red. DO NOT UNSCREW THE TWO PHILLIPS



You access the gas flow adjustment screw



Use a flat head screw driver to adjust the height of the flame: turn clockwise = decrease height turn counter clockwise = increase height

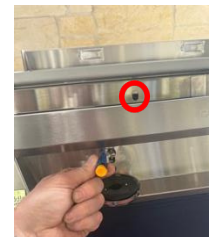

Easy adjustment: lower the top panel and remove the grease trays you can see the flame through the clearance to the front.



Your griddle is set, then reinstall the bezel and the knob.

COMMERCIAL SERIES



Light on your griddle by Following instruction Page 24 and place the knob on the low position



Remove the knob by pulling gently



You access the gas flow adjustment screw



Use a flat slotted screw driver to adjust the height of the flame: turn clockwise = decrease height turn counterclockwise = increase height



Your griddle is set, then reinstall the knob

PARTS & DIAGRAM

PRO SERIES

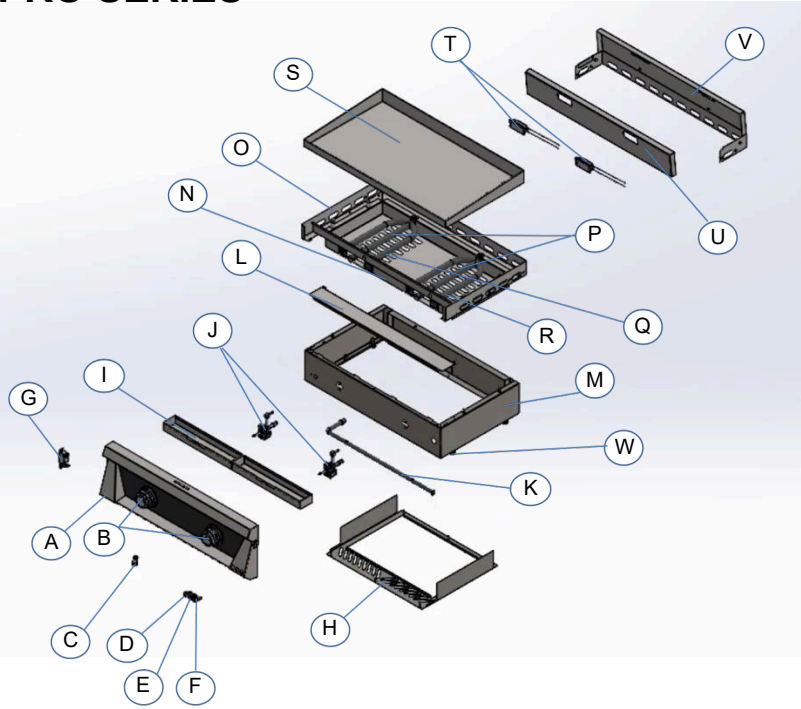

COMMERCIAL SERIES

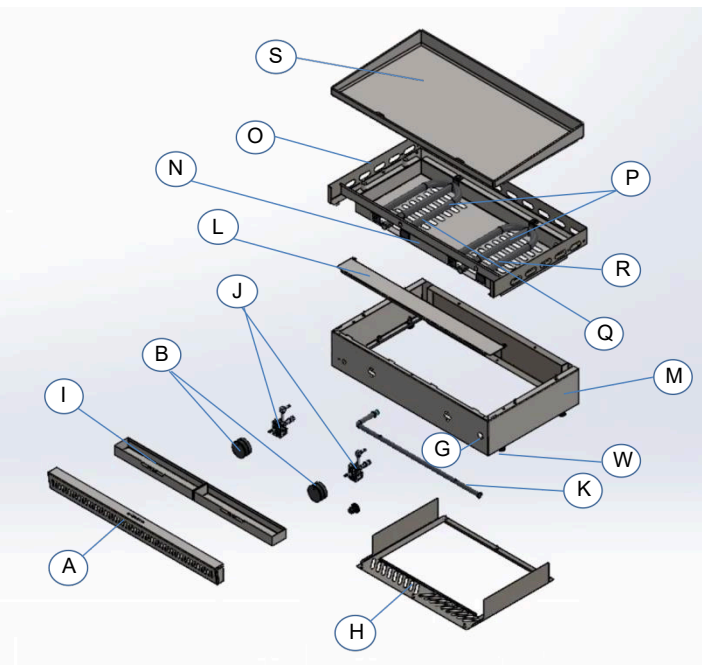

Rep.	Item	SKU#	Rep.	Item	SKU#
A	Front Panel	Pro Series CC.155/156/157	N	Separation Tray Part	Both Series CC.170/171/172
		Commercial CC.158/159	O	Ventilated Angle Part	Both Series CC.173/174/175
B	Knob + Bezel	Pro Series CC.112+CC.113	P	Burner	Both Series CC.001
		Commercial CC.019+CC.030	Q	Thermocouple	Both Series CC.007
C	Logo Spotlight	Pro Series CC.114	R	High Temp Ignition Wire Short	Both Series CC.027
D	Push Button Flame Logo	Pro Series CC.117	R	High Temp Ignition Wire Medium	Both Series CC.028
E	Push Button Sun Logo	Pro Series CC.118	R	Hi Temp Ignition Wire Long	Both Series CC.029
F	Push Button Bulb Logo	Pro Series CC.119	S	Cooking Plate	Both Series CC.106/107/108/110/111
G	Igniter Box	Pro Series CC.143/144/145	T	Halogen Lamp	Pro Series CC.115
		Commercial CC.095/096 +CC.182	U	Light Box Front Part	Pro Series CC.176/177/178
H	Bottom Part	Both Series CC.160/161/162	V	Light Box Back Part	Pro Series CC.179/180/181
I	Grease Tray	Both Series CC.163	W	Adjustable Feet	Pro Series CC.004
J	Gas Valves	Pro Series CC.031			Commercial CC.032
			Commercial CC.146	X	Wire Harness Short
K	Gas Manifold Ramp	Both Series CC.014/015/016	Y	Wire Harness Medium	Pro Series CC.098
L	Valve Enclosure Part	Both Series CC.164/165/166	Z	Wire Harness Long	Pro Series CC.099
M	Body Part	Both Series CC.167/168/169			



Le Griddle offers one of the best warranties in the industry:

Series	Residential	Apartments / Multi-Family Use	Commercial / Restaurant Use
Pro Series			
3mm Plate	Lifetime Warranty	1 Year Warranty	1 Year Warranty
6mm Plate			
Body	5 Year Warranty		
Burners + Valves	10 Year Warranty		
Electronics	1 Year Warranty		
Commercial Series			
3mm Plate	Lifetime Warranty	1 Year Warranty	1 Year Warranty
6mm Plate		10 Year Warranty	10 Year Warranty
Body	5 Year Warranty	5 Year Warranty	5 Year Warranty
Burners + Valves	10 Year Warranty	1 Year Warranty	1 Year Warranty
Electronics	1 Year Warranty		
Electric Series			
Plate	Lifetime Warranty	No Warranty	No Warranty
Body			
Burners + Valves	10 Year Warranty		
Electronics	1 Year Warranty		
Accessories			
Carts	10 Year Warranty	1 Year Warranty	1 Year Warranty
Trim Kits & Liners			
Lids			
Covers	1 Year Warranty		
Cooking Accessories			

We take great care to ensure that each of our appliances reaches the user in perfect operating condition. If you discover any issues when unpacking your appliance, please report it to the retailer within 48 hours. If the appliance is not functioning properly, please contact your retailer or email us at CS@LeGriddle.com. This nontransferable warranty is limited to the replacement of original, defective parts (one-time replacement) and does not cover shipping or labor for removal or installation of replacement parts, if necessary.

The following are not covered by the guarantee:

- Deformation of the plate when it is too hot. This deformation is not permanent and will disappear when the plate cools; it is normal in use.
- Normal wear of the product that does not affect its operation (scratches, color change, etc.).
- The presence of rust, cracks, or other deformation of the cast-iron surface that does not affect the appliance's operation.
- Damage caused by abnormal use, modification of the product, or failure to follow the instructions for use (using chlorine-based cleaning products).
- Damage resulting from a fall or impact. Please do not hesitate to contact us should you have any questions or suggestions at CS@LeGriddle.com.

Failure to follow the instructions outlined in the owner's manual may also void warranty coverage.

This non-transferable warranty is limited to a one-time replacement of original defective parts and does not include shipping or labor costs associated with the removal or installation of replacement parts.

The original owner must retain and provide proof of purchase when submitting a warranty claim. Product registration is not required.